

# SERIES 200



# SERIES 200

## MANUAL

### TABLE OF CONTENTS

	PAGE
PRODUCT OVERVIEW .....	3-4
TECHNICAL PRODUCT DETAILS .....	5
PERFORMANCE .....	6
DIMENSIONAL DATA .....	7
RECEIVING/INSTALLATION/MOUNTING .....	8-9
APPLICATION OVERVIEW .....	10
CONFIGURATION & SETUP .....	11
VALVE SETUP (VARIABLE VOLUME) .....	12-13
VALVE SETUP (CONSTANT VOLUME) .....	14-15
VALVE SETUP (DUAL SETPOINT) .....	16-17
COMMISSIONING .....	18-19
NETWORK SETUP AND TROUBLESHOOTING .....	20
BACNET® POINTS .....	21
I/O DIAGNOSTICS .....	22
OPTIONAL ACCESSORIES .....	23

### IMPORTANT NOTES

⚠ This symbol highlights crucial information related to the Series 200. Failure to adhere to proper installation, wiring, and setup guidelines may result in malfunction. It is essential to closely review all cautionary notes throughout this manual.

Additionally, Recommendations and ⚠ Notes are provided throughout each section. These suggestions are based on CRC's experience and are generally applicable in most scenarios. However, please verify them against industry standards and project-specific requirements.

### NOTES

Before starting up and commissioning the Series 200, ensure you familiarize yourself with the unit, its controls, options, and accessories. All personnel involved in commissioning should be well-versed in the start-up procedures and have access to the necessary guides and tools for reference.

### LOCAL SUPPORT

For product support, please reach out to your local Critical Room Control channel partner.

Additional information is available at [www.criticalroom.com](http://www.criticalroom.com).

## PRODUCT OVERVIEW

The Series 200 is an independent air control valve designed for precise, maintenance-free airflow management and seamless integration with third-party control systems. Utilizing CRC's patented CLV air valve technology, it delivers industry-leading performance with exceptionally low pressure drop and a wide operating range of 0–7,800 CFM, maintaining  $\pm 5\%$  airflow accuracy across its entire range. Equipped with full network connectivity, the Series 200 ensures reliable and efficient airflow control with streamlined system compatibility.



## SERIES 200 OPERATION MODES

- **Variable Volume:** Adjusts and maintains a precise airflow setpoint based on an external analog signal.
- **Constant Volume:** Regulates a fixed, single airflow setpoint for consistent performance.
- **Dual Setpoint:** Switches between two discrete airflow set points, controlled by an external relay signal.

## KEY FEATURES

- **Commissioned Accuracy:** Airflow accuracy of less than  $\pm 5\%$  with a minimum of 10 to 1 turndown.
- **Energy Efficient:** Low-pressure-drop design supports static pressures as low as 0.25 inches WC, reducing operating costs.
- **Patented Indirect Sensing Technology:** Maintains unobstructed airflow paths, resistant to duct-borne contaminants.
- **Flexible Installation:** No inlet/outlet restrictions, with unrestricted mounting orientation and axis installation options.
- **Advanced Damper Design:** Engineered for precise airflow control and superior damper authority, with the capability for full closure.
- **Long-Term Repeatability:** Delivers consistent performance with no scheduled maintenance required.
- **High-Capacity Airflow Range:** Supports airflow rates from 0 to 7,800 CFM.
- **Durable Construction:** Built for both corrosive and non-corrosive environments, with stainless steel construction and optional protective coatings for extreme conditions.
- **High-Speed Actuation:** Compatible with both Fail-Safe and Fail-In-Place operation modes for rapid response.
- **Multiple Actuation Options:** Configurable for high-speed actuation to meet various control needs.
- **Fail-Safe & Fail-In-Place Modes:** Provides dependable operation under diverse conditions.

# SERIES 200

## MANUAL

### PRODUCT OVERVIEW

#### SERIES 200 APPLICATIONS

The Series 200 is designed to support multiple airflow control applications, including:

- **Variable Volume:** Modulates airflow based on an external control signal.
- **Constant Volume:** Maintains a fixed airflow setpoint.
- **Dual Setpoint:** Switches between two predefined airflow setpoints.

#### SERIES 200 OPERATING MODES

##### VARIABLE VOLUME

When set to Variable Volume mode, the Series 200 air valve modulates airflow to maintain a setpoint based on a hard-wired scaled voltage signal, typically provided by a Building Automation System (BAS) controller.

- The input signal can be configured for 0-5VDC, 2-10VDC, or 0-10VDC.
- The corresponding airflow setpoint range is determined by the valve size.
- A purge setpoint can be optionally configured.

##### CONSTANT VOLUME

When set to Constant Volume mode, the Series 200 air valve maintains a fixed airflow setpoint at all times.

- The setpoint can be adjusted via the touchscreen interface or BACnet®.
- An optional purge setpoint can be configured.

##### DUAL SETPOINT

In Dual Setpoint mode, the Series 200 air valve regulates airflow to maintain either a primary (Setpoint A) or secondary (Setpoint B) airflow setpoint.

- A hardwired digital input, such as an externally supplied switch, can trigger the transition between setpoints.
- Setpoints can be adjusted via the touchscreen interface or BACnet®.
- An optional purge setpoint can also be configured.



### TECHNICAL PRODUCT DETAILS

#### CHARACTERISTICS AND PERFORMANCE

<b>Valve Connection</b>	Slip fit w/ band clamps, dual plates, or sheet metal screws
<b>Mounting Orientation</b>	Universal, any orientation or axis
<b>Commissioned Accuracy</b>	±5 % (Pressure independent)
<b>Input Power</b>	24 VAC ±5 %, 50/60 Hz 106 to 116: 30 VA, 212 to 216: 60 VA
<b>Speed of Response</b>	≤ 1 Second
<b>Designed Max APD</b>	0.25 inWC

#### ENVIRONMENTAL LIMITATIONS

<b>Operating Temperature</b>	-4 °F to 175 °F (-20 °C to 79 °C), 5 to 95 % RH non-condensing
<b>Storage Temperature</b>	-40 °F to 175 °F (-40 °C to 79 °C), 5 to 95 % RH non-condensing

#### VALVE CONSTRUCTION

Size	Type	Description	Construction			
			Non-Corrosive		Corrosive	
			Valve Body	Damper & Shaft	Valve Body	Damper & Shaft
106 - 112	Single Valve	Single Valve 6", 8", 10", 12"	E-Coated Galvanized Steel	Stainless Steel	Stainless Steel	Stainless Steel
114 - 116	Single Valve	Single Valve 14" & 16"	Aluminum	Stainless Steel	Stainless Steel	Stainless Steel
212 - 216	Dual valve	Dual Valve 2-12", 2-14", 2-16"	Aluminum	Stainless Steel	Stainless Steel	Stainless Steel

#### VALVE ACTUATION AND ACCESSORIES

Size	Type	Description	Fail Position		Optional Accessories	
			Option 1	Option 2	Band Clamps	Insulation
106 - 112	Single Valve	Single Valve 6", 8", 10", 12"	Fail In Place	Fail Safe	✓	✓
114 - 116	Single Valve	Single Valve 14" & 16"	Fail In Place	Fail Safe	✓	✓
212 - 216	Dual valve	Dual Valve 2-12", 2-14", 2-16"	Fail In Place	Fail Safe	✗	✓

#### VALVE MODEL INFORMATION

Unit Size	K Factor	Flow Range (CFM)	Flow Range (LPS)
106	450	0-600	0-283
108	775	0-1050	0-495
110	1250	0-1700	0-802
112	2600	0-2600	0-1228
114	2275	0-3200	0-1510
16	2967	0-4200	0-1982
212	3377	0-4700	0-2218
214	4597	0-6400	0-3020
216	6000	0-8400	0-3964

#### NOMENCLATURE

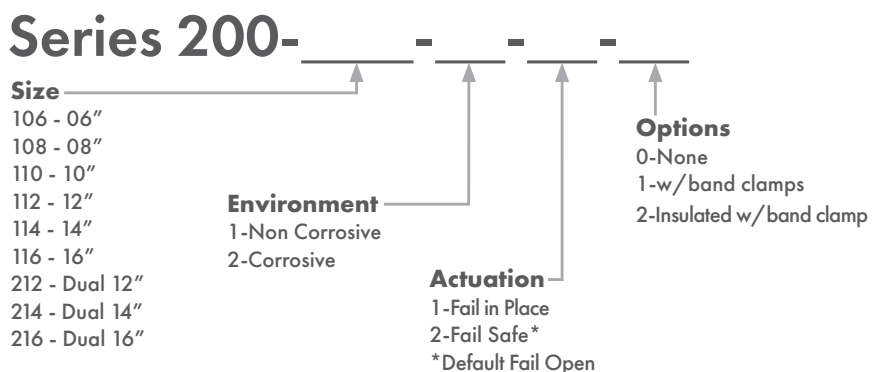

# SERIES 200

## MANUAL

### PERFORMANCE

#### SERIES 200 PERFORMANCE DATA

Valve Size	Eng. Units	±20%	≤15%	≤7%	Optimal Performance Design Range										Max CFM	Valve Size
					≤5%	≤3%	≤2%	≤1%	≤1%	≤1%	≤1%	≤1%	≤1%	≤1%		
106	CFM	0-30	30	40	60	100	120	220	300	380	440	480	540	600	106	
108	CFM	0-60	60	80	100	160	200	360	540	680	800	900	980	1050	108	
110	CFM	0-80	80	140	170	300	400	640	900	1140	1320	1440	1600	1700	110	
112	CFM	0-160	160	200	240	380	560	920	1420	1720	2000	2280	2500	2900	112	
114	CFM	0-180	180	240	310	540	800	1200	1720	2100	2420	2700	2960	3100	114	
116	CFM	0-210	210	315	420	700	1000	1580	2210	2730	3125	3520	3850	4200	116	
212	CFM	0-230	230	350	460	660	1100	1760	2520	3040	3520	3800	4100	4600	212	
214	CFM	0-360	360	480	600	1080	1600	2400	3240	4200	4840	5200	5400	6000	214	
216	CFM	0-420	420	630	780	1400	2000	3160	4420	5460	6250	6800	7200	7800	216	
ΔPS	inWC	≤0.005	≤0.005	≤0.005	≤0.005	0.01	0.02	0.05	0.10	0.15	0.20	0.25	0.30	inWC	ΔPS	

#### SERIES 200 PERFORMANCE CHART

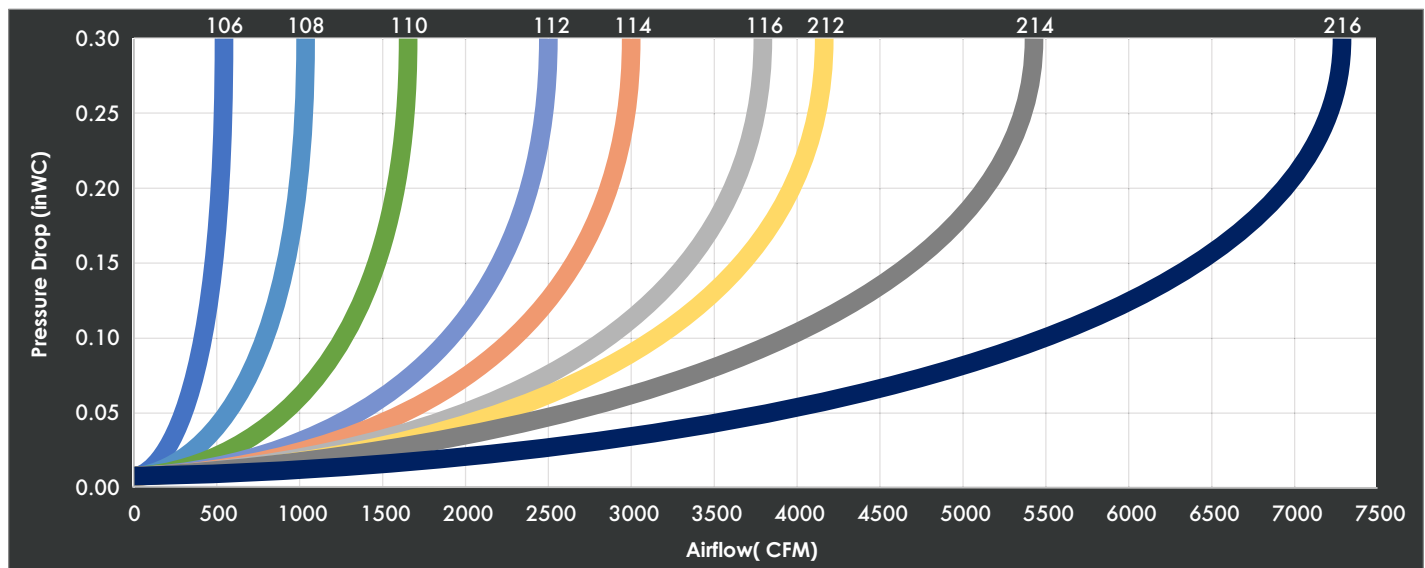

⚠ To achieve optimal energy-efficient performance, choose a valve size that maintains a maximum pressure drop of 0.25" at the design airflow rate.

### DIMENSIONAL DATA

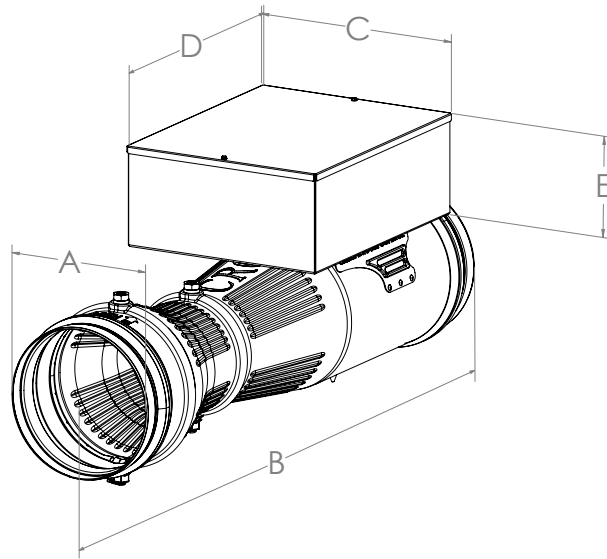

#### SERIES 200 SINGLE CLV

Valve Size	A	B	C	D	E
	in [mm]	in [mm]	in [mm]	in [mm]	in [mm]
106	5.9 [149]	28.5 [724]*	13.6 [345]	17.1 [435]	6.5 [165]
108	7.9 [200]	34.8 [884]*	13.6 [345]	17.1 [435]	6.5 [165]
110	9.9 [251]	39.3 [998]*	13.6 [345]	17.1 [435]	6.5 [165]
112	11.9 [302]	40.5 [1029]*	13.6 [345]	17.1 [435]	6.5 [165]
114	13.9 [352]	48.0 [1220]	13.6 [345]	17.1 [435]	6.5 [165]
116	15.9 [381]	48.0 [1220]	13.6 [345]	17.1 [435]	6.5 [165]

\*Length measurement is taken from gasket to gasket to account for the slip-fit connection.

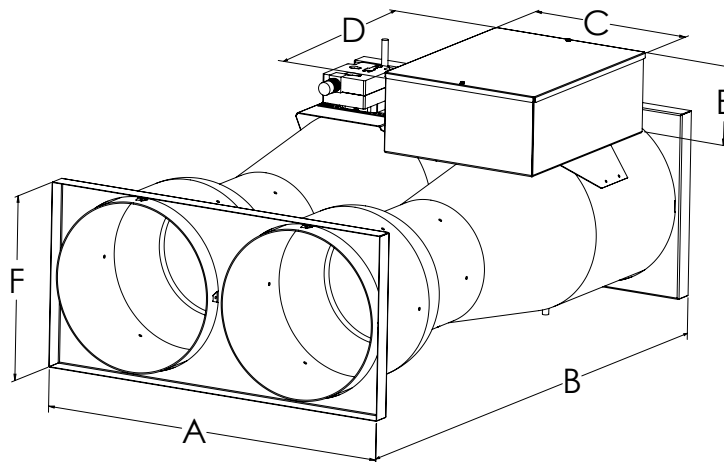

#### SERIES 200 DUAL CLV

Valve Size	A	B	C	D	E	E
	in [mm]	in [mm]	in [mm]	in [mm]	in [mm]	in [mm]
212	26.0 [660]	48.0 [1220]	13.6 [345]	17.1 [435]	6.5 [165]	13.0 [165]
214	30.0 [762]	48.0 [1220]	13.6 [345]	17.1 [435]	6.5 [165]	15.0 [165]
216	34.0 [864]	48.0 [1220]	13.6 [345]	17.1 [435]	6.5 [165]	17.0 [165]

### RECEIVING AND INSTALLATION

#### SAFETY PRECAUTIONS

- Carefully read all instructions before beginning installation.
- Ensure all installation work, including electrical wiring, complies with applicable codes and standards.
- Adhere to all fire ratings during installation.
- Wear appropriate protective gear, including eyewear, gloves, and clothing, suitable for the working environment.
- The manufacturer assumes no responsibility for personal injury or property damage resulting from improper installation, service, or product handling.
- Deviation from specifications or drawings may lead to product damage, additional site work, and delays in system delivery.

#### RECEIVING INSTRUCTIONS

- Inspect all equipment thoroughly upon receipt for shipping damage. Document any damage with a detailed description.
- Immediately report any damage or loss to the delivering carrier.
- Notify the carrier in person or by phone and follow up

#### PRIOR TO INSTALLATION

- Visually inspect the valve for any signs of damage.
- Confirm that the valve size, material, and coatings are appropriate for the installation location.
- Ensure all packing materials are removed from the valve.
- Check the valve label to verify its correct location and function (refer to Figure 1).

#### INSTALLATION PROCEDURE

- Support all ductwork within 18 inches (18") of the air valve.
- Verify that the airflow direction in the duct matches the airflow direction indicated on the valve (refer to Figure 2).
- Maintain a minimum clearance of 12 inches (12") of free space around the air valve for access.
- Install the air valve in any orientation that allows easy access to the enclosure (refer to Figure 3).

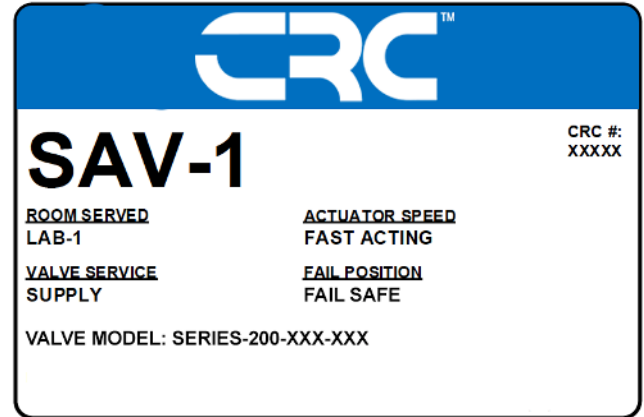

Figure 1

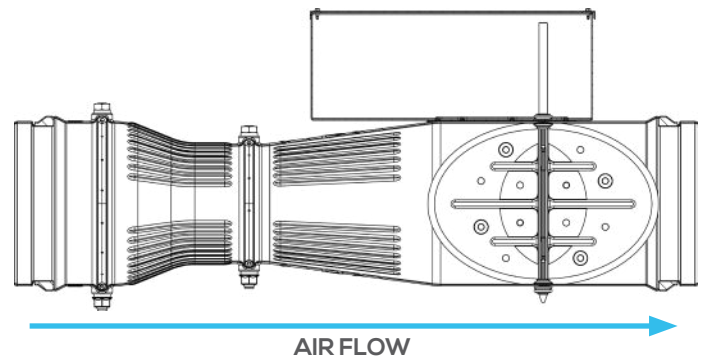

Figure 2



Figure 3

## RECEIVING/INSTALLATION/MOUNTING

### SLIP-FIT CONNECTION INSTRUCTIONS

#### 1. Valve Installation:

Insert the Series 200 inlet and outlet into the properly sized ductwork.

#### 2. Support:

Secure the ductwork with hangers within 18 inches (18") of both the inlet and outlet of the Series 200.

#### 3. Fastening:

Attach the air valve to the ductwork using a minimum of six (6) sheet metal screws (see Figure 4). Ensure screws do not interfere with the Series 200 operation or airflow.

#### 4. Sealing:

Seal the ductwork connections with the specified duct sealer (see Figure 5).

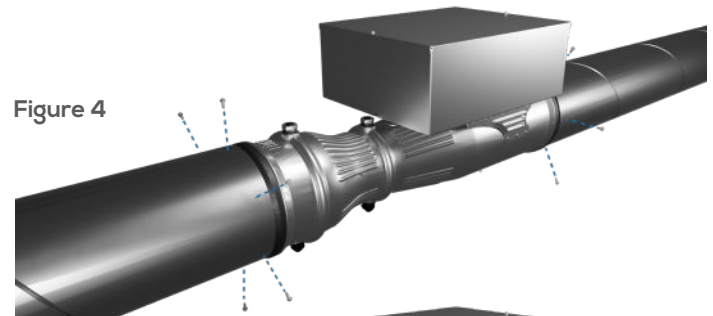

Figure 4

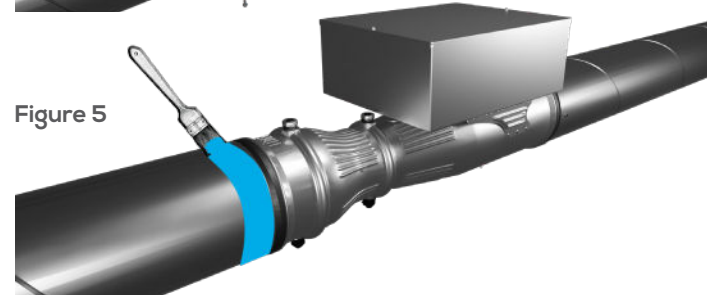

Figure 5

### SLIP-FIT WITH BAND CLAMPS INSTRUCTIONS

#### 1. Prepare Draw Band Clamps:

Slide draw band clamps onto the inlet and discharge ductwork (refer to Figure 6).

#### 2. Valve Installation:

Insert the Series 200 inlet and outlet into the appropriately sized ductwork.

#### 3. Seal the Connection:

Apply duct tape to seal the connection between the Series 200 and ductwork as specified.

#### 4. Support:

Secure the ductwork with hangers within 18 inches (18") of both the inlet and outlet of the Series 200.

#### 5. Position Band Clamps:

Slide the draw band clamps over the connection points between the Series 200 and the ductwork (refer to Figure 7).

#### 6. Tighten Clamps:

Tighten the draw band clamps around both the Series 200 body and the ductwork to secure the connection.

#### 7. Avoid Screws:

Do not use screws to secure the band clamps.



Figure 6



Figure 7

**⚠ Band Clamp Bead Position:** Ensure the band clamp bead is correctly positioned on the duct, not on the air valve body.

# SERIES 200

## MANUAL

### APPLICATION OVERVIEW

The Series 200, integrating CRC's patented CLV air valve technology, provides high-precision airflow control across three distinct operating modes: standalone variable volume control driven by an analog input from an external third-party controller, constant volume control, and dual setpoint control activated via third-party relay signaling. As a standalone device, it achieves exceptional accuracy and reliability by harnessing the venturi effect. Designed for optimal performance, the Series 200 offers minimal pressure drop and an industry-leading turndown ratio, ensuring superior efficiency and rapid responsiveness in critical airflow applications.

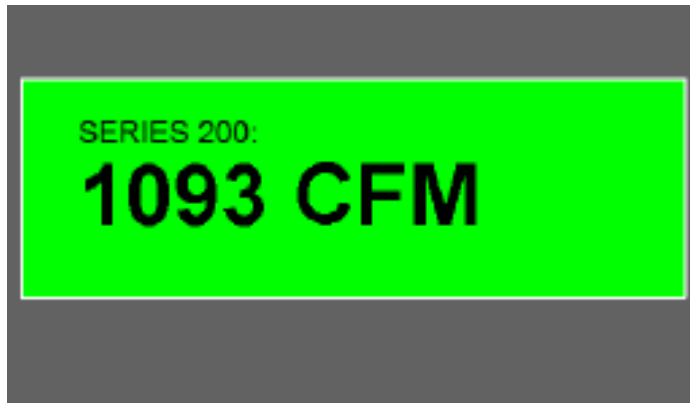

#### VARIABLE VOLUME

The Variable Volume Series 200 is a standalone air valve designed to maintain precise airflow control based on a third-party linear analog voltage signal, typically from a Building Automation System (BAS) controller. This hard-wired, scaled voltage signal — configurable as 0-5VDC, 2-10VDC, or 0-10VDC — corresponds to the desired airflow setpoint. The valve continuously modulates airflow to maintain this setpoint, with the setpoint range determined by the valve size.

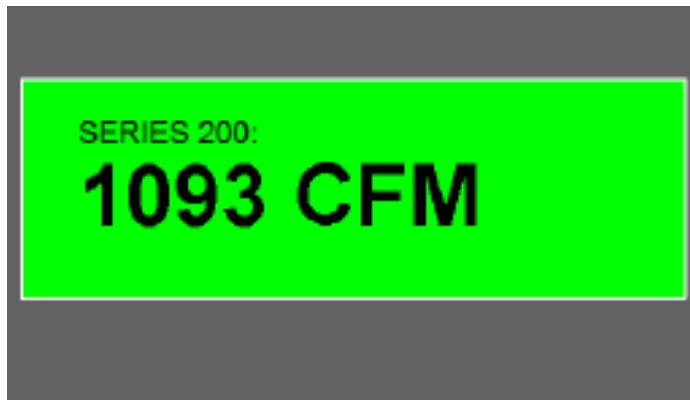

#### CONSTANT VOLUME

When set to Constant Volume mode, the Series 200 air valve maintains a fixed airflow setpoint, adjustable via the touch-screen programming tool or over BACnet®.

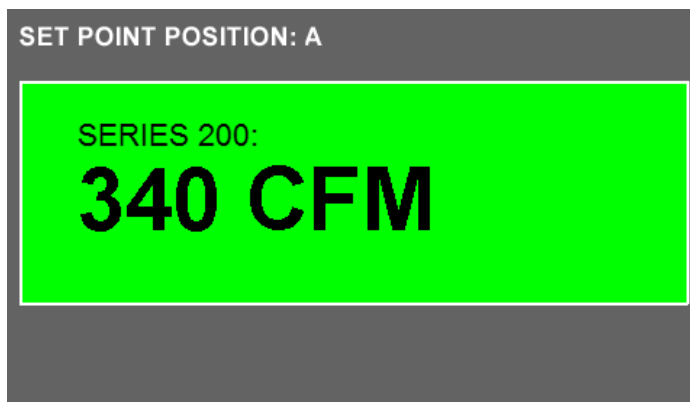

#### DUAL SETPOINT

In Dual Setpoint mode, the Series 200 air valve maintains airflow at either a primary (Setpoint A) or secondary (Setpoint B) setpoint. A hardwired digital input, such as an externally supplied switch, triggers the transition between setpoints. Both setpoints can be adjusted using the touch-screen programming tool or over BACnet®.

## CONFIGURATION & SETUP

The Series 200 is factory pre-configured for Variable Volume operation with a 0-10V input signal, ensuring seamless installation and immediate operational readiness.

- If the application requires Constant Volume or Dual Setpoint operation, the Field Commissioning Tool must be used to select the desired mode and enter the appropriate flow setpoints.
- All other settings are factory-optimized to minimize installation complexity, allowing for a hassle-free startup.

### **The Series 200 can be configured for one of the following control strategies:**

- Variable Volume (Input 0-10V) (Default Setup)
- Variable Volume (Input 0-5V)
- Variable Volume (Input 2-10V)
- Constant Volume
- Dual Setpoint

The following section provides detailed information on Series 200 operation, setup, and configuration parameters. This guidance is intended for advanced applications, custom configurations, or troubleshooting as needed.

### VALVE SETUP (Variable Volume)

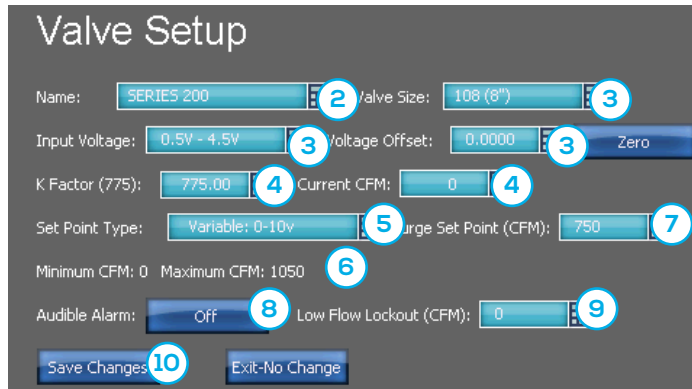

When configured for variable voltage operation, the Series 200 air valve modulates airflow to maintain a setpoint dictated by a hardwired scaled voltage signal, typically supplied by a BAS controller. The input signal can be configured for 1-5VDC, 2-10VDC, or 0-10VDC. The corresponding setpoint range is determined by the valve size. Additionally, a purge setpoint can be configured.

### VARIABLE VOLUME VALVE SETUP PROCEDURE

- 1 **Accessing the Valve Setup Screen:** Touch the Valve Setup option to open the setup screen.
- 2 **Name:** Enter the valve's name, tag, or identifier.
- 3 **Valve Size, Input Voltage, and Voltage Offset:** These settings are pre-configured during the manufacturing process.
- 4 **K Factor and Current CFM:** These parameters will be addressed during the commissioning process.
- 5 **Set Point Type:** Select "Dual Position" for the set point type.
- 6 **Variable Volume Input Scale CFM:** Corresponding external input scale (in CFM) for selected voltage scale.
- 7 **Purge Set Point (CFM):** Enter the purge set point if applicable.
  - ⚠ If purge mode is not used, this value can be ignored.
- 8 **Audible Alarm:** The audible alarm is not utilized.
- 9 **Low Flow Lockout (CFM):** Pre-set and does not require adjustment.
- 10 **Save Changes:** Ensure to save any changes made to the settings.

### VALVE MODEL INFORMATION

Unit Size	K Factor	Flow Range (CFM)	Flow Range (LPS)
106	450	0-600	0-283
108	775	0-1050	0-495
110	1250	0-1700	0-802
112	2600	0-2600	0-1228
114	2275	0-3200	0-1510
116	2967	0-4200	0-1982
212	3377	0-4700	0-2218
214	4597	0-6400	0-3020
216	6000	0-8400	0-3964

### WIRING GUIDE (Variable Volume)

- 1 **BACnet® MS/TP Connection:** Supports communication via BACnet® MS/TP protocol.
- 2 **Field Programming Tool:** Utilizes a CAT6 connector for configuration and programming.
- 3 **Setpoint Input Signal:** Accepts an analog input from a third-party device, providing a linear airflow setpoint based on the Series 200 size and corresponding CFM range (refer to the applicable flow chart).
- 4 **Damper Position Output:** Provides a 0-10V analog output signal indicating damper position, where 0.0V = 100% closed and 10.0V = 100% open.
- 5 **Airflow Output:** Outputs a 0-10VDC linear analog signal representing airflow in CFM, scaled according to the Series 200 size (refer to the Series 200 Airflow Range Chart for details).
- 6 **Isolation Transformer:** 24VAC Isolation transformer supplied by CRC, wired to both board and actuator.
  - ⚠ Customer should land wiring (hot and neutral) at factory installed connectors.
- 7 **Purge Activation Input:** Engages the purge mode when a third-party relay is closed, driving the Series 200 to the designated purge CFM setpoint.
- 8 **Purge Activation Output:** A relay closes when the Series 200 enters purge mode, enabling secondary indication for third-party devices (e.g., local alarm or strobe).
- 9 **Flow Alarm:** A relay activates if the Series 200 airflow fails to maintain the setpoint for more than 60 seconds. This function is only active when the alarm is enabled.

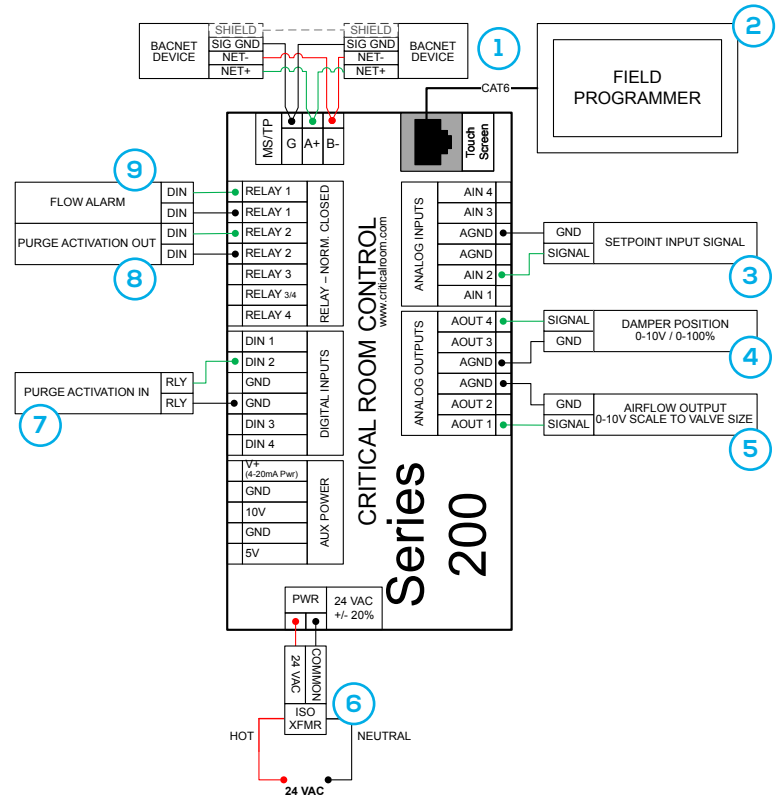

### VALVE SETUP (Constant Volume)

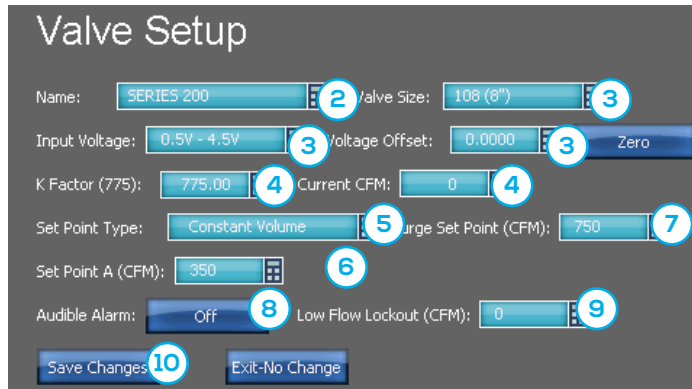
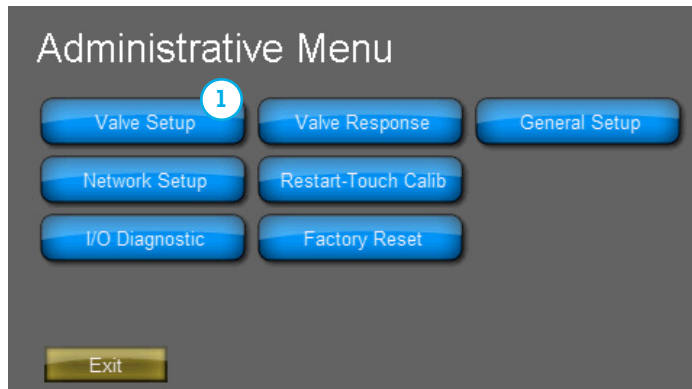

When configured for constant volume, the Series 200 air valve maintains a single airflow setpoint at all times. The setpoint can be adjusted via the touchscreen or over BACnet®, with an optional purge setpoint also available.

#### VALVE SETUP PROCEDURE

- 1 **Access Valve Setup:** Tap Valve Setup to open the configuration screen.
- 2 **Name:** Enter the valve name, tag, or identifier.
- 3 **Factory-Set Parameters:** Valve Size, Input Voltage, and Voltage Offset are pre-configured during manufacturing.
- 4 **K Factor and Current CFM:** These values will be addressed in the Commissioning section.
- 5 **Set Set Point Type:** Select Constant Volume as the set point type.
- 6 **Set Point A (CFM):** Enter the desired airflow control set point.
- 7 **Purge Set Point (CFM):** Enter the purge set point if applicable.
  - ⚠ If purge mode is not used, this value can be ignored.
- 8 **Audible Alarm:** This feature is not used.
- 9 **Low Flow Lockout (CFM):** Pre-set and does not require adjustment.
- 10 **Save Changes:** Ensure any modifications are saved before exiting.

#### VALVE MODEL INFORMATION

Unit Size	K Factor	Flow Range (CFM)	Flow Range (LPS)
106	450	0-600	0-283
108	775	0-1050	0-495
110	1250	0-1700	0-802
112	2600	0-2600	0-1228
114	2275	0-3200	0-1510
116	2967	0-4200	0-1982
212	3377	0-4700	0-2218
214	4597	0-6400	0-3020
216	6000	0-8400	0-3964

### WIRING GUIDE (Constant Volume)

- 1 **BACnet® MS/TP Connection:** Supports communication via BACnet MS®/TP protocol.
- 2 **Field Programming Tool:** Utilizes a CAT6 connector for configuration and programming.
- 3 **Damper Position Output:** Provides a 0-10V analog output signal indicating damper position, where 0.0V = closed and 10.0V = 100% open.
- 4 **Airflow Output:** Outputs a 0-10VDC linear analog signal representing airflow in CFM, scaled according to the Series 200 size (refer to the Series 200 Airflow Range Chart for details).
- 5 **Isolation Transformer:** 24VAC Isolation transformer supplied by CRC, wired to both board and actuator.
  - ⚠ Customer should land wiring (hot and neutral) at factory installed connectors.
- 6 **Purge Activation Input:** Engages the purge mode when a third-party relay is closed, driving the Series 200 to the designated purge CFM setpoint.
- 7 **Purge Activation Output:** A relay closes when the Series 200 enters purge mode, enabling secondary indication for third-party devices (e.g., local alarm or strobe).
- 8 **Flow Alarm:** A relay activates if the Series 200 airflow fails to maintain the setpoint for more than 60 seconds. This function is only active when the alarm is enabled.

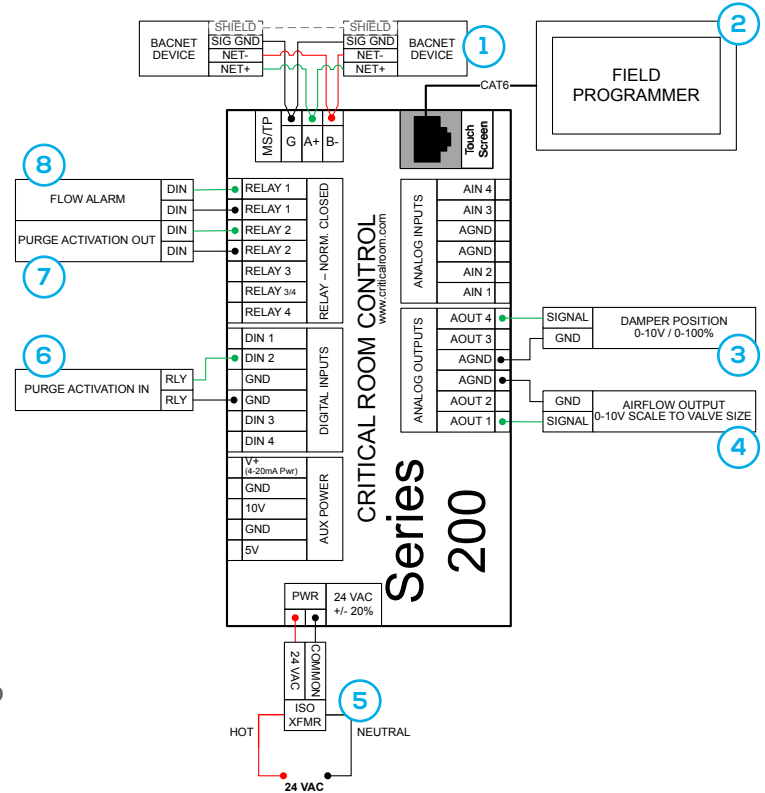

### VALVE SETUP (Dual Setpoint)

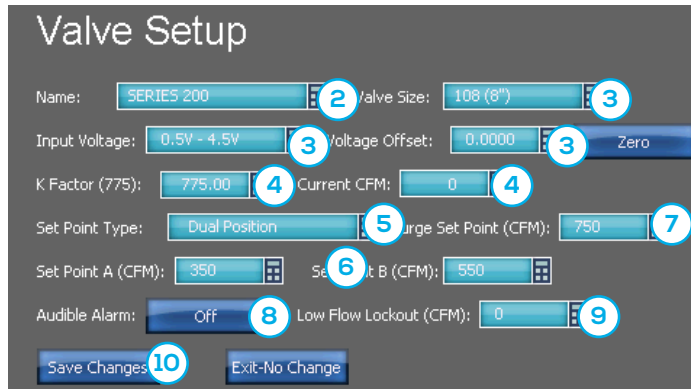
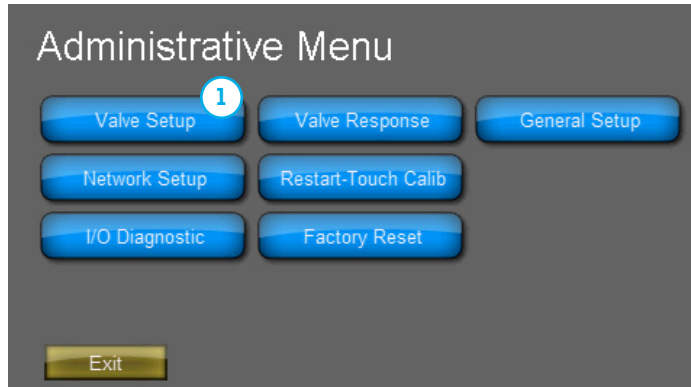

### VALVE MODEL INFORMATION

Unit Size	K Factor	Flow Range (CFM)	Flow Range (LPS)
106	450	0-600	0-283
108	775	0-1050	0-495
110	1250	0-1700	0-802
112	2600	0-2600	0-1228
114	2275	0-3200	0-1510
116	2967	0-4200	0-1982
212	3377	0-4700	0-2218
214	4597	0-6400	0-3020
216	6000	0-8400	0-3964

When configured for dual-position operation, the Series 200 air valve regulates airflow to maintain either a primary (A) or secondary (B) setpoint. A hardwired digital input, such as an externally supplied switch, can initiate the transition between setpoints. Setpoint adjustments can be made via the optional touchscreen interface or over BACnet®, with an optional purge setpoint also configurable.

### VALVE SETUP PROCEDURE

- 1 Access Valve Setup:** Tap Valve Setup to open the configuration screen.
- 2 Name:** Enter the valve name, tag, or identifier.
- 3 Factory-Set Parameters:** Valve Size, Input Voltage, and Voltage Offset are pre-configured during manufacturing.
- 4 K Factor and Current CFM:** These values will be addressed in the Commissioning section.
- 5 Set Point Type:** Select “Dual Setpoint” for the set point type.
- 6 Set Point A (CFM) and Set Point B (CFM):**  
Set Point A: Enter the primary control set point.  
Set Point B: Enter the secondary control set point.
- 7 Purge Set Point (CFM):** Enter the purge set point if applicable.  
 If purge mode is not used, this value can be ignored.
- 8 Audible Alarm:** The audible alarm is not utilized.
- 9 Low Flow Lockout (CFM):** Pre-set and does not require adjustment.
- 10 Save Changes:** Ensure to save any changes made to the settings before exiting

### WIRING GUIDE (Dual Setpoint)

- 1 **BACnet® MS/TP Connection:** Supports communication via BACnet® MS/TP protocol.
- 2 **Field Programming Tool:** Utilizes a CAT6 connector for configuration and programming.
- 3 **Damper Position Output:** Provides a 0-10V analog output signal indicating damper position, where 0.0V = 100% closed and 10.0V = 100% open.
- 4 **Airflow Output:** Outputs a 0-10VDC linear analog signal representing airflow in CFM, scaled according to the Series 200 size (refer to the Series 200 Airflow Range Chart for details).
- 5 **Isolation Transformer:** 24VAC Isolation transformer supplied by CRC, wired to both board and actuator.
  - ⚠ Customer should land wiring (hot and neutral) at factory installed connectors.
- 6 **Purge Activation Input:** Engages the purge mode when a third-party relay is closed, driving the Series 200 to the designated purge CFM setpoint.
- 7 **Setpoint A/B Selection:** Allows the Series 200 to switch between two distinct CFM setpoints. Controlled by a third-party relay, where Open = Setpoint A and Closed = Setpoint B.
- 8 **Purge Activation Output:** A relay closes when the Series 200 enters purge mode, enabling secondary indication for third-party devices (e.g., local alarm or strobe).
- 9 **Flow Alarm:** A relay activates if the Series 200 airflow fails to maintain the setpoint for more than 60 seconds. This function is only active when the alarm is enabled.

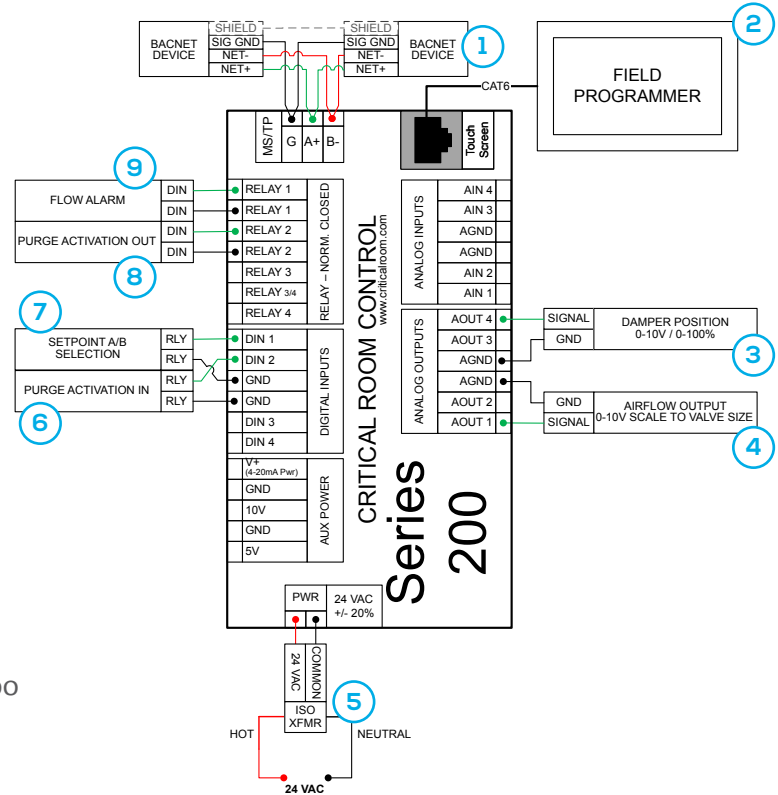

### COMMISSIONING

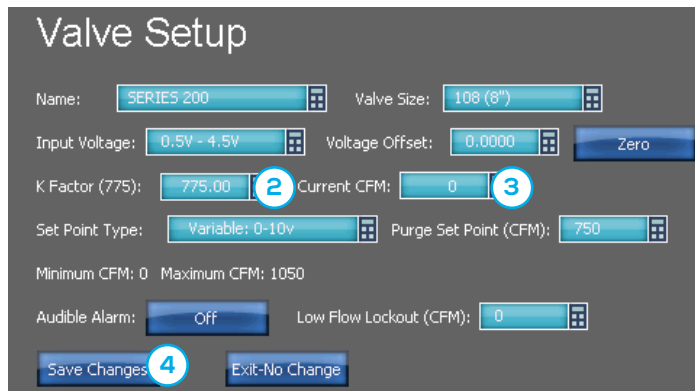
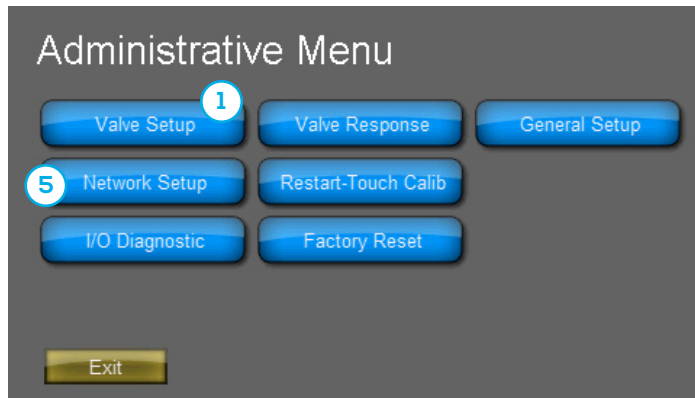

### VALVE MODEL INFORMATION

Unit Size	K Factor	Flow Range (CFM)	Flow Range (LPS)
106	450	0-600	0-283
108	775	0-1050	0-495
110	1250	0-1700	0-802
112	2600	0-2600	0-1228
114	2275	0-3200	0-1510
116	2967	0-4200	0-1982
212	3377	0-4700	0-2218
214	4597	0-6400	0-3020
216	6000	0-8400	0-3964

The Series 200 is pre-configured at the factory and is also designed for field commissioning. The following section outlines the procedures and details for field commissioning the Series 200.

### VALVE SETUP PROCEDURE (BALANCING)

- 1 Access the Valve Setup Screen:** Tap the “Valve Setup” option to open the configuration screen.
  - 2 K Factor Default Setting:** The K Factor will be pre-set to a default value based on the valve size during manufacturing.
  - 3 Field Measure Airflow (CFM):** Measure the airflow (CFM) through the air valve. After measurement, input the airflow value into the “Current CFM” field. The K Factor will automatically update based on the entered “Current CFM.”
  - 4 Save Changes:** Save the changes once balancing is complete.
- ⚠** The final K Factor should be within  $\pm 5\%$  of the default value for the applicable valve size. Refer to the table on the left for additional valve details.
- 5 Balancing Over BACnet®:** Ensure that the Network Setup has been completed (see the Network Setup section). Measure the airflow (CFM) through the air valve. After measurement, input the airflow value into point AV 1 (Flow Rate). The K Factor will automatically recalculate based on the airflow entered in AV 1 and will be reflected in point AV 4 (K Factor).

## COMMISSIONING



The Series 200 is factory pre-configured for optimal performance in most applications. The response configuration allows for adjustments to the system's reaction speed when responding to setpoint changes and maintaining the setpoint under varying duct conditions

### VALVE SETUP PROCEDURE (RESPONSE)

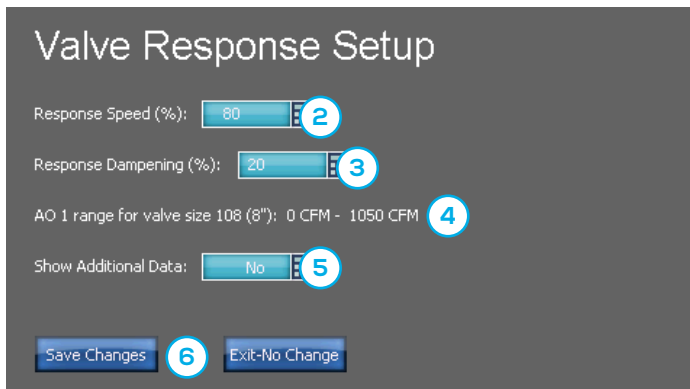

- 1 **Access the Valve Response Screen:** Tap the “Valve Response” option to open the Valve Response settings.
- 2 **Response Speed (%):** This setting controls how quickly the air valve modulates to reach the set point. Increase the value to speed up the response. Decrease the value to slow down the response.

#### Recommended: 80% (Factory default)

⚠ Increasing Response Speed too much may cause “hunting” behavior, where the air valve continuously oscillates above and below the set point.

- 3 **Response Dampening (%):** This setting controls how much the air valve response slows down as it approaches the set point. Increase the value to slow the response. Decrease the value to speed up the response.

#### Recommended: 20% (Factory default), which is the minimum value.

⚠ Excessive Response Dampening may result in the valve responding too slowly, which can negatively affect performance.

- 4 **AO 1 Range for Valve Size:** This indicates the flow capacity of the air valve for the selected size.
- 5 **Show Additional Data:** This option is not used.
- 6 **Save Changes:** Ensure to save any edits made to the settings.

### NETWORK SETUP AND TROUBLESHOOTING

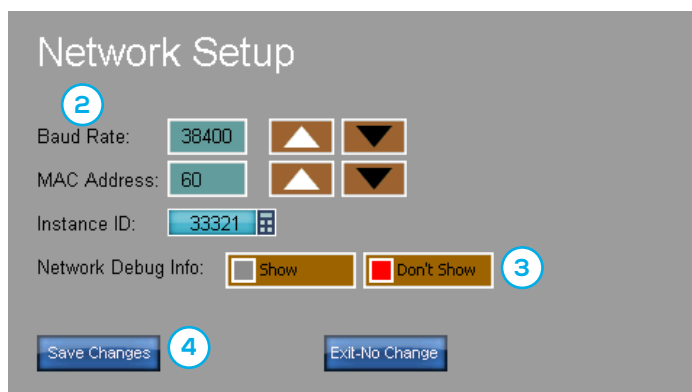
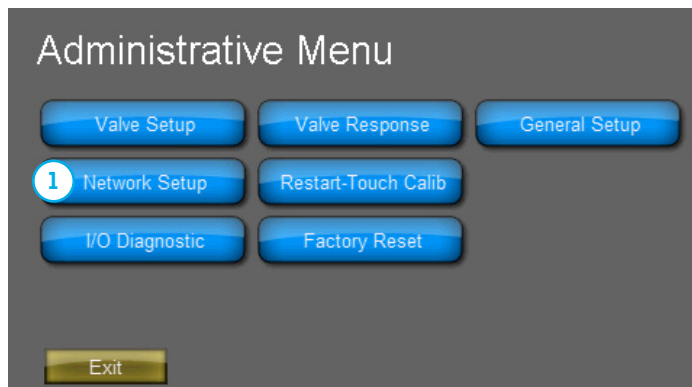

```

BAUD:38400 MAC: 35 Instance ID: 35
Network Traffic: 14128
M IN: 0 S ACK: 0 C ACK: 0 M SENT: 1149
Who Is: 0 Who Is (R): 0 I Am: 1 Token: 617
ABORT: 0 REJECT: 0 ERROR: 0
CRC Errors Header(DLL): 0 Data: 0
Possible Noise Framing Err: 0 Break Err: 0
Token Gen: 0 Lost Neigh.(PFM): 0
    
```

#### NETWORK SETUP

- 1 **Access the Network Setup Screen:** Tap the “Network Setup” option to open the network configuration screen.
- 2 **Enter BACnet® MS/TP Network Parameters:**  
 Baud Rate: Select one of the following options: 9600, 19200, 38400, 57600, 76800, or 115200.  
 MAC Address: Enter a value between 0 and 254.  
 Instance ID: Enter a value between 1 and 4,194,304.
  - ⚠ Ensure all devices on the trunk have unique MAC addresses, and each device on the BAS network must have a unique Instance ID.
- 3 **Network Debug Information:** Displays network communication details on the screen.
  - Recommended: Only enable this option when troubleshooting communication issues (see below).**
- 4 **Save Changes:** Save any changes made to the network configuration.

#### TROUBLESHOOTING

**Network Traffic:** This value increases when there is network activity, regardless of whether the device’s baud rate is set correctly. If the value isn’t increasing, check the wiring and ensure the network setup for all devices is correct.

**M In (Messages In):** Increases when this device receives a message specifically addressed to it.

**S ACK (Simple Acknowledgement):** Increases when the device receives a message requesting it to write a value.

**C ACK (Complex Acknowledgement):** Increases when the device responds to a request for data.

**M SENT (Messages Sent):** Increases when the device sends a message, including passing a token.

**Who Is:** Increases when the device receives a “Who Is” message.

**Who Is (R) (Ranged Who Is):** Increases when the device receives a “Who Is” request for a specific range of Instance IDs.

**I Am:** Increases when the device sends an “I Am” response to a “Who Is” request.

⚠ If “I Am” is not increasing alongside “Who Is,” it may be because the “Who Is” request was limited to a range outside this device’s Instance ID or the device is not receiving a token.

**Token:** Increases when the device receives and passes a token. If the number is not increasing, check the wiring and confirm the devices’ network setup is accurate.

**Possible Noise Framing Error / Break Error:** If the numbers are increasing, this may indicate issues such as:

- Electrical noise on the trunk
- Multiple devices with the same MAC address
- Missing reference ground for RS-485 (note: shield cannot be used as ground)

### BACnet® POINTS

#### SERIES 200 BACnet® POINTS LIST

Object	Point Name	Description	Units	Range	Read/Write
AV1	Flow Rate	Series 200 Measured Airflow (Should only be written to for commissioning)	CFM/ LPS	0-999999	R/W
AV2	Current SP (Setpoint)	Series 200 Setpoint	CFM/ LPS	0-999999	R
AV3	Valve Position (Damper)	Damper position: 0% = Full Closed 100% Full Open	%	0-100	R
AV4	K Factor	Series 200 K Factor	N/A	0-999999	R/W
AV5	Override Valve Pos (Damper Override)	Series 200 Damper override: -1 = no override 0 Full Closed 100 Full Open	%	-101	R/W
AV6	Flow Alarm	Alarm state 1 = No alarm 2 = High flow alarm 3 = Low flow alarm	N/A	1,2,3	R
AV7	Set Point A	Set point for Constant Volume and Dual Setpoint	CFM/ LPS	0-999999	R/W
AV8	Set Point B	Set point 2 for Dual Setpoint (Used for Dual Setpoint only)	CFM/ LPS	0-999999	R/W
AV9	Purge Set Point	Set point for when valve is in purge mode (CFM)	CFM/ LPS	0-999999	R/W
AV10	Set Point Mode	Current State for Constant Volume and Dual Setpoint 1 = Set point A 2 = Set point B 3 = Purge set point	N/A	1,2,3	R/W
AV11	Resp. Speed 0-500%	Series 200 Response Speed 0 = Slowest 500 = Fastest	%	0-500	R/W
AV12	Resp. Damp 0-500%	Series 200 Response Speed 0 = Slowest 500 = Fastest	%	0-500	R/W
AV13	Valve Size	Series 200 Model: ST106: 6" Inlet (Range 0-600 CFM) ST108: 8" Inlet (Range 0-1050 CFM) ST110: 10" Inlet (Range 0-1700 CFM) ST112: 12" Inlet (Range 0-2600 CFM) SP114: 14" Inlet (Range 0-3400 CFM) SP116: 16" Inlet (Range 0-4200 CFM) SP212: Dual 12" Inlet (Range 0-4700 CFM) SP214: Dual 14" Inlet (Range 0-6400 CFM) SP216: Dual 16" Inlet (Range 0-8400 CFM)	CFM	0-999999	R/W
AV14	Aud Alarm	Audible Alarm State 1 = No Alarm 2 = Audible Alarm 3 = Alarm Muted	N/A	1,2,3	R/W
AV15	Low Flow Lockout	Low Flow Lockout Value	CFM/ LPS	0-1000	R/W
AV16	Smoothing Factor	Commissioning Tool Display Smoothing Factor 0 = No Smoothing Applied 100 = Maximum Smoothing Applied	%	0-99	R/W

BACnet® is a registered trademark of ASHRAE

# SERIES 200

## MANUAL

### I/O DIAGNOSTICS

This screen is used to validate the wiring and operational status of the Series 200. In this mode, all automatic control is overridden, enabling manual operation through analog output sliders and digital output switches. Upon exiting the diagnostic screen, the Series 200 automatically resumes standard control mode.

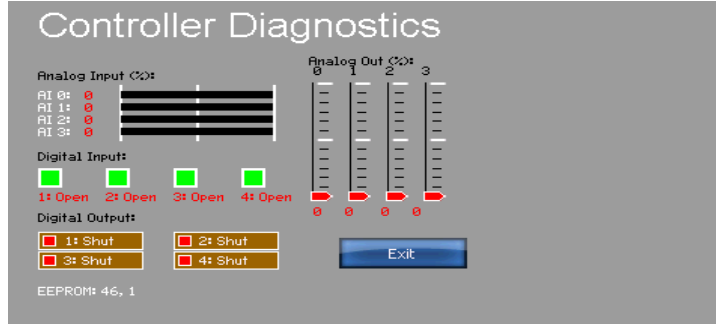

### I/O DIAGNOSTICS PARAMETERS

Parameter	Unit Selections	Description	Series 200 Applications
Analog Input 1	0-100% (0-10V)	Series 200 Flow feedback signal (0.5 to 4.5v)	Variable Volume Constant Volume Dual Setpoint
Analog Input 2	0-100% (0-10V)	Input signal for airflow setpoint	Variable Volume
Analog Input 3	0-100% (0-10V)	Not Used	Not Used
Analog Input 4	0-100% (0-10V)	Not Used	Not Used
Analog Output 1	0-100% (0-10V)	Linear Airflow Output signal 0-10V	Variable Volume Constant Volume Dual Setpoint
Analog Output 2	0-100% (0-10V)	Factory wired signal to Series 200 Actuator	Variable Volume Constant Volume Dual Setpoint
Analog Output 3	0-100% (0-10V)	Not Used	Not Used
Analog Output 4	0-100% (0-10V)	Series 200 Damper Position 0 - 10v / 0 - 100% Open	Variable Volume Constant Volume Dual Setpoint
Digital Input 1	Open Closed	Set Point A/B trigger Open: Setpoint A Closed: Setpoint B	Dual Setpoint
Digital Input 2	Open Closed	Purge mode trigger Open: Purge Mode Not Active Closed: Purge Mode Active	Variable Volume Constant Volume Dual Setpoint
Digital Input 3	Open Closed	Not Used	Not Used
Digital Input 4	Open Closed	Not Used	Not Used
Relay 1	Open Closed	Flow Alarm Status Open: No Alarm Closed: Alarm	Variable Volume Constant Volume Dual Setpoint
Relay 2	Open Closed	Purge mode status: Closed: Not in Purge Mode Open: In Purge Mode	Variable Volume Constant Volume Dual Setpoint
Relay 3	Open Closed	Not Used	Not Used
Relay 4	Open Closed	Not Used	Not Used

### OPTIONAL ACCESSORIES

#### BAND CLAMPS



Top View

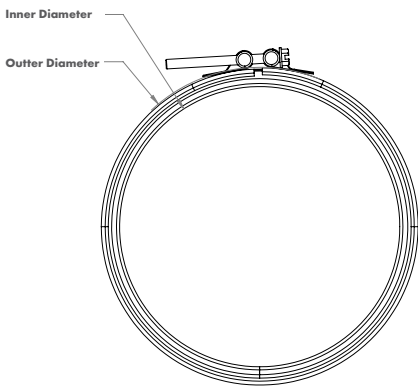

Side View

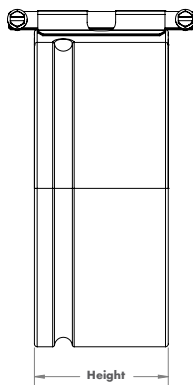

#### CHARACTERISTICS

<b>Material of Construction</b>	Galvanized Steel
<b>Gasket</b>	UL94 Neoprene
<b>Design</b>	Dual-Bolt
<b>Torque</b>	Not to exceed 40 in-lbs
<b>Band Clamps provided in sets of (2)</b>	

#### SIZE CHART

Part #	Inner Diameter	Outer Diameter	Height
BC-106	[136.65] 5.38	[159.93] 6.3	[89.33] 3.52
BC-108	[187.45] 7.38	[211.93] 8.34	[89.5] 3.52
BC-110	[238.25] 9.38	[262.73] 10.34	[89.5] 3.52
BC-112	[289.05] 11.38	[313.53] 12.34	[89.5] 3.52
BC-114	[339.85] 13.38	[364.33] 14.34	[89.5] 3.52
BC-116	[390.65] 15.38	[415.13] 16.34	[89.5] 3.52

#### INSULATION



#### CHARACTERISTICS

<b>Material of Construction</b>	Closed-cell elastomeric thermal insulation
<b>Gasket</b>	0.25" (6.4 mm)
<b>Design</b>	R-1.0

#### ENVIRONMENTAL LIMITATIONS

<b>Upper Temperature Limit</b>	220 °F (104 °C)
<b>Lower Temperature Limit</b>	-297 °F (-183 °C)
<b>Flame Spread and Smoke Developed Index</b>	25/50 rated

⚠ Valve insulation is factory installed

#### Key

[BRACKETS] = MILLIMETERS (mm)

NO BRACKETS = INCHES (in)

criticalroom.com



**Measure What Matters.**

Critical Room Control  
9275 North 49th Street  
Brown Deer, WI 53223

414.324.8978  
Sales@criticalroom.com